



**GPS & GLONASS Receiver Module**  
**MR31009EBGG**

## Revision History

Date	Reversion	Description
2021/12/20	1.0	First Draft, Based on MR31009EBGG

## Directory

<b>Revision History</b> .....	2
<b>1. Product Information</b> .....	4
1.1 Product Description .....	4
1.2 Product Features .....	4
1.3 Product Specifications .....	5
1.4 DC Electrical Characteristics .....	6
<b>2. Block Diagram</b> .....	7
<b>3. Module Pin Assignment</b> .....	7
3.1 Pin Descriptions .....	8
<b>4. Dimensions</b> .....	9
<b>5. Recommended Footprint</b> .....	9
<b>6. Application Circuit</b> .....	10
6.1 Application Circuit of MR31009EBGG .....	10
6.2 Layout Notes .....	10
<b>7. Reflow Profile</b> .....	11
<b>8. Tape &amp; Reel</b> .....	11
<b>9. Software Interface</b> .....	12
<b>10. Protocol</b> .....	13
10.1 GGA – Global Positioning System Fix Data .....	13
10.2 GLL – Latitude/Longitude .....	14
10.3 GSA – GPS & GLONASS DOP and Active Satellites .....	15
10.4 GSV – GPS & GLONASS Satellites in View .....	16
10.5 RMC – Recommended Minimum Specific GNSS Data .....	17
10.6 VTG – Course Over Ground and Ground Speed .....	18

## 1. Product Information

### 1.1 Product Description

MR31009EBGG features high sensitivity, low power and ultra small form factor. The module is powered by GOKE, which provides superior sensitivity and performance even in urban canyon and dense foliage environment. The miniature size makes the module easy to integrate into portable device like mobile phone, PDAs, camera and vehicle locators.

Through the feature of 66-channel, the MR31009EBGG boasts a hot start in less than 1 second. Innovative design and technology suppresses jamming sources and mitigates multipath effects, assisting excellent navigation performance.

### Applications

- Automotive Navigation
- Personal Positioning
- Fleet Management
- Marine Navigation

### 1.2 Product Features

- Build on High Performance, Low-Power GOKE chipset
- Ultra High Track Sensitivity: -165dBm
- Built in High Gain LNA
- Extremely Fast TTFF at Low Signal Level
- NMEA-0183 Compliant Protocol or Custom Protocol
- RoHS Compliant

## 1.3 Product Specifications

GPS Receiver		
Chip	GOKE	
Frequency	Code 66 search channels, 22 synchronous tracking channels GPS&, QZSS, GALILEO: L1 1575.42MHz C/A GLONASS: L1OF 1602MHz BeiDou: B1 1561.098MHz SBAS: WAAS, EGNOS, MSAS, GAGAN	
Update Rate	1Hz (default) , up to 10Hz	
Position Accuracy	Position	<2.5m CEP @-130 dBm
	Accuracy of 1PPS Signal	Typical accuracy: ±10ns / Time pulse width 100ms
	Acceleration Accuracy	Without aid: 0.1m/s <sup>2</sup>
Startup Time	Cold start	35s typ @-130dBm
	Warm start	30s typ @-130dBm
	Hot start	1s typ @-130dBm
Sensitivity	Acquisition	-148Bm
	Re-acquisition	-156Bm
	Tracking	-165dBm
GNSS Operating limit	Altitude	18,000m
	Velocity	515m/s
	Acceleration	4G
Protocol Support	UART Port: TXD and RXD 9600bps (default), Baud rate supports 4800bps to 460800bps NMEA 0183 Protocol	
Environment	Operation temperature	-40°C ~ +85°C
	Storage temperature	-45°C ~ +125°C
Physical Characteristics	Size	10.1±0.15 × 9.7±0.15 × 2.2±0.1mm
	Weight	Approx. 0.41g

## 1.4 DC Electrical Characteristics

Parameter	Min.	Typ.	Max.	Units
Input Voltage	2.8	3.3	4.3	Volt
Acquisition		38		mA
Tracking		36		mA
Backup Battery		20		uA
Low Level Output Voltage (VOL)			0.4	Volt
High Level Output Voltage (VOH)	2.4			Volt
Low Level Input Voltage (VIL)			0.8	Volt
High Level Input Voltage (VIH)	2			Volt
Low Level Output Current (IOL)		2		mA
High Level Output Current (IOH)		2		mA

## 2. Block Diagram

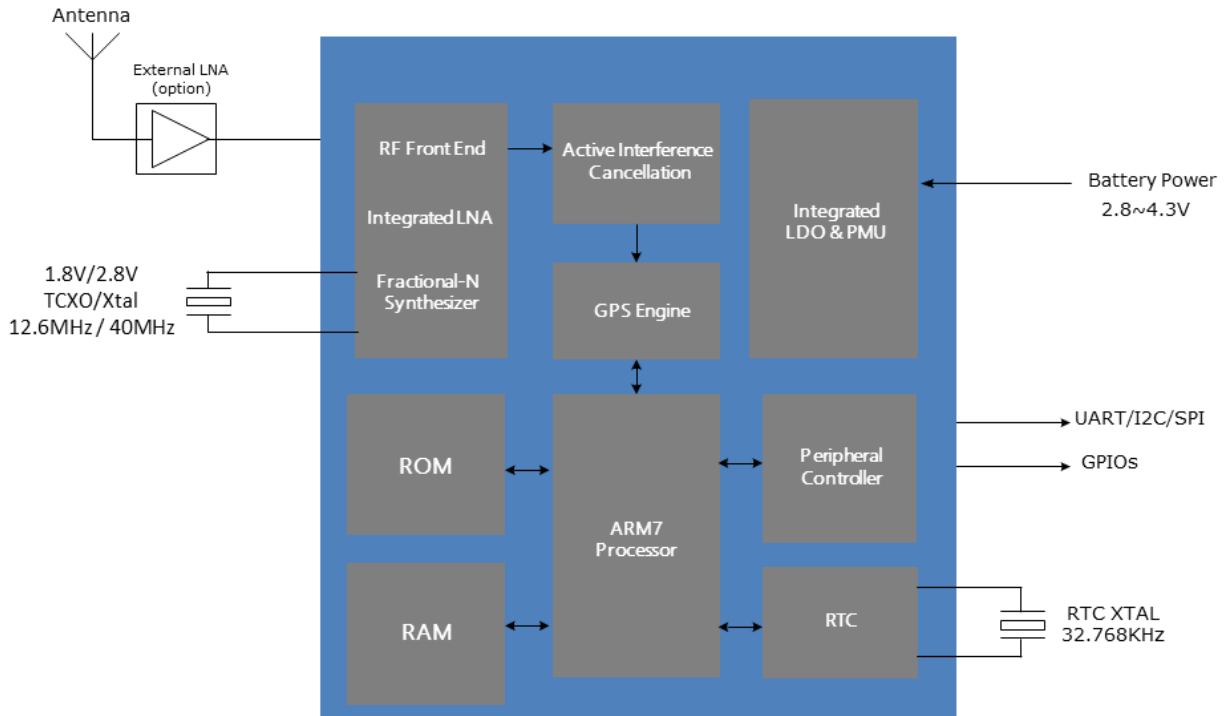

## 3. Module Pin Assignment

<b>10</b>	GND	RESET	<b>9</b>
<b>11</b>	RF_IN	VCC	<b>8</b>
<b>12</b>	GND	NC	<b>7</b>
<b>13</b>	NC	VBAT	<b>6</b>
<b>14</b>	VCC_RF	GPIO0	<b>5</b>
<b>15</b>	NC	PPS	<b>4</b>
<b>16</b>	TXB	RXA	<b>3</b>
<b>17</b>	RXB	TXA	<b>2</b>
<b>18</b>	GPIO1	GND	<b>1</b>

**MR31009EBGG**  
Top View

## 3.1 Pin Descriptions

Pin NO.	Pin Name	Remark
1	GND	Ground
2	TXA	UART serial data output
3	RXA	UART serial data input
4	PPS	Time pulse (1PPS) (if not used, must be left floating)
5	GPIO0	General purpose I/O
6	VBAT	Backup battery supply voltage
7	NC	No connection
8	VCC	Main power supply to the engine board
9	RESET	System reset
10	GND	Ground
11	RF_IN	RF signal input
12	GND	Ground
13	NC	No connection
14	VCC_RF	Output power supply for external LNA or active antenna
15	NC	No connection
16	TXB	UART serial data output
17	RXB	UART serial data input
18	GPIO1	General purpose I/O



## 4. Dimensions

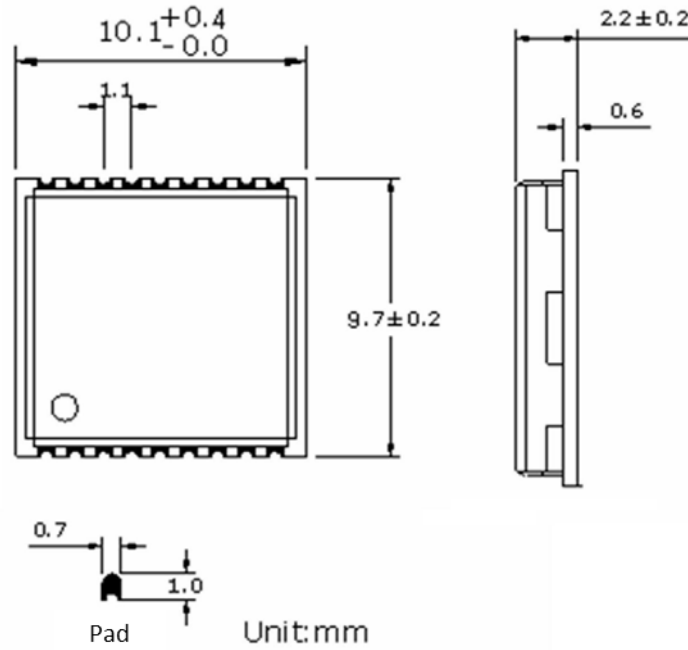

## 5. Recommended Footprint

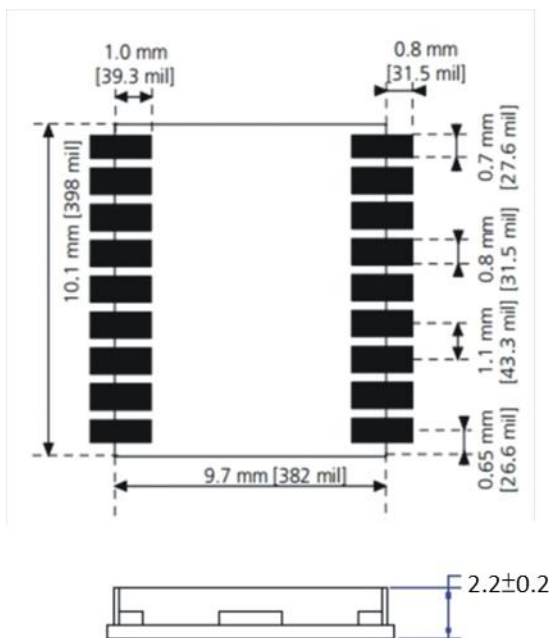

## 6. Application Circuit

### 6.1 Application Circuit of MR31009EBGG

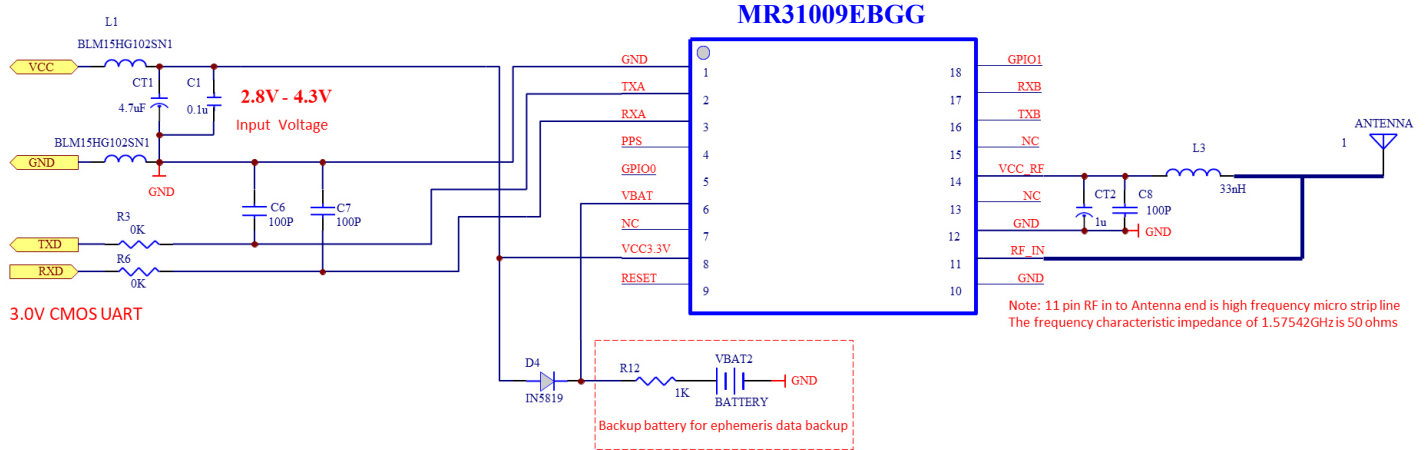

### 6.2 Layout Notes

1. A decoupling capacitor should be placed close to VDD pin of the module, and the width of power routing should be more than 0.5mm.
2. The characteristic impedance of RF routing between RF port to antenna should be controlled to 50  $\Omega$ .
3. Do not place the module close to any EMI source, RF routing, clock signal or other high-frequency switching signal, etc.



## 9. Software Interface

NMEA	Description
GGA	GGA Global positioning system fixed data
GLL	GLL Geographic position—latitude/longitude
GSA	GNSS DOP and active satellites
GSV	GNSS satellites in view
RMC	RMC Recommended minimum specific GNSS data
VTG	VTG Course over ground and ground speed

## 10. Protocol

### 10.1 GGA – Global Positioning System Fix Data

For example:

\$xxGGA, 161229.487,3723.2475,N, 12158.3416,W, 1,07,1.0,9.0,M.0000\*18

Field	Name	Example	Units	Description
1	Message ID	\$xxGGA		GGA protocol header
2	UTC Position	161229.487		hhmmss.sss
3	Latitude	3723.2457		ddmm.mmmm
4	N/S indicator	N		N=north or S=south
5	Longitude	12158.3416		dddmm.mmmm
6	E/W Indicator	W		E=east or W=west
7	Position Fix Indicator	1		See Table 10.1-1
8	Satellites Used	07		Range 0 to 12
9	HDOP	1.0		Horizontal Dilution of Precision
10	MSL Altitude	9.0	meters	
11	Units	M	meters	
12	Geoids Separation		meters	
13	Units	M	meters	
14	Age of Diff.Corr.		second	Null fields when DGPS is not Used
15	Diff.Ref.Station ID	0000		
16	Check sum	*18		
18	<CR> <LF>			End of message termination

Table 10.1-1 Position Fix Indicators

Value	Description
0	Fix not available or invalid
1	GPS & Glonass SPS Mode, fix valid
2	Differential GPS & Glonass, SPS Mode, fix valid
3	GPS & Glonass PPS Mode, fix valid

## 10.2 GLL – Latitude/Longitude

For example:

\$xxGLL , 3723.2475, N,12158.3416, W,161229.487, A\*2C

Field	Name	Example	Units	Description
1	Message ID	\$xxGLL		GLL protocol header
2	Latitude	3723.2475		ddmm.mmmm
3	N/S Indicator	N		N=north or S=south
4	Longitude	12158.3416		dddmm.mmmm
5	E/W Indicator	W		E=east or W=west
6	UTC Position	161229.487		hhmmss.sss
7	Status	A		A=data valid or V=data not valid
8	Check sum	*2C		
9	<CR> <LF>			End of message termination

## 10.3 GSA – GPS & GLONASS DOP and Active Satellites

For example:

\$xxGSA , A, 3, 07, 02, 26,27, 09, 04,15, , , , , , 1.8,1.0,1.5\*33

Field	Name	Example	Units	Description
1	Message	\$xxGSA		GSA protocol header
2	Mode 1	A		See Table 10.3-1
3	Mode 2	3		See Table 10.3-2
4	Satellite Used	07		Sv on Channel 1
5	Satellite Used	02		Sv on Channel 2
6	...	...		...
7	Satellite Used			Sv on Channel 66
8	PDOP	1.8		Position Dilution of Precision
9	HDOP	1.0		Horizontal Dilution of Precision
10	VDOP	1.5		Vertical Dilution of Precision
11	Check sum	*33		
12	<CR> <LF>			End of message termination

Table 10.3-1 Mode 1

Value	Description
1	Fix not available
2	2D
3	3D

Table 10.3-2 Mode2

Value	Description
M	Manual-forced to operate in 2D or 3D mode
A	Automatic-allowed to automatically switch 2D/3D

## 10.4 GSV – GPS & GLONASS Satellites in View

For example :

\$xxGSV , 2, 1, 07, 07, 79,048, 42, 02, 51,062, 43, 26, 36,256, 42, 27, 27, 138,42\*71

\$xxGSV, 2, 2, 07, 09, 23,313, 42, 04, 19, 159, 41, 15,12,041, 42\*41.

Field	Name	Example	Units	Description
1	Message ID	\$xxGSV		GSV protocol header
2	Number of Message	2		Range 1 to 3
3	Message Number	1		Range 1 to 3
4	Satellites in View	07		
5	Satellite ID	07		Channel 1(Range 1 to 66)
6	Elevation	79	degrees	Channel 1(Maximum 90)
7	Azinmuth	048	degrees	Channel 1(True, Range 0 to 359)
8	SNR(C/NO)	42	dBHz	Range 0 to 99,null when not tracking
9	...			...
10	Satellite ID	27		Channel 4(Range 1 to 66)
11	Elevation	27	degrees	Channel 1(Maximum 90)
12	Azimuth	138	degrees	Channel 1(True, Range 0 to 359)
13	SNR(C/NO)	42	dBHz	Range 0 to 99,null when not tracking
14	Check sum	*71		
15	<CR> <LF>			End of message termination



## 10.5 RMC – Recommended Minimum Specific GNSS Data

For example:

\$xxRMC, 161229.487, A, 3723.2475, N, 12158.3416, W, 0.13,309.62, 120598,, \*10

Field	Name	Example	Units	Description
1	Message ID	\$xxRMC		RMC protocol header
2	UTS Position	161229.487		hhmmss.sss
3	Status	A		A=data valid or V=data not valid
4	Latitude	3723.2475		ddmm.mmmm
5	N/S Indicator	N		N=north or S=south
6	Longitude	12158.3416		dddmm.mmmm
7	E/W Indicator	W		E=east or W=west
8	Speed Over Ground	0.13	Knots	
9	Course Over	309.62	Degrees	True
10	Ground			
11	Date	120598		Dummy
12	Magnetic variation		Degrees	E=east or W=west
13	Check sum	*10		
14	<CR> <LF> End of			End of message termination

## 10.6 VTG – Course Over Ground and Ground Speed

For example:

\$xxVTG, 309.62, T, M, 0.13, N, 0.2, K\*6E

Field	Name	Example	Units	Description
1	Message ID	\$xxVTG		VTG protocol header
2	Course	309.62	Degrees	Measured heading
3	Reference	T		True
4	Course		Degrees	Measured heading
5	Reference	M		Magnetic
6	Speed	0.13	Knots	Measured horizontal speed
7	Units	N		Knots
8	Speed	0.2	Km/hr	Measured horizontal speed
9	Units	K		Kilometer per hour
10	Check sum	*6E		
11	<CR> <LF>			End of message termination